

INSIDE VIEW

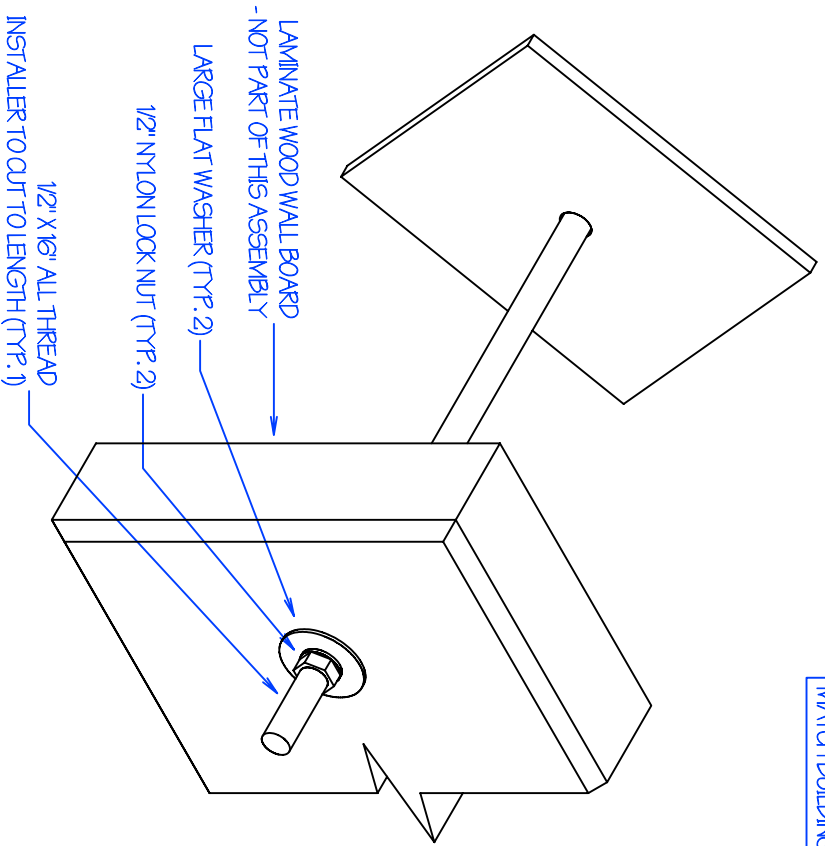

6" SQ. STEEL PLATES WILL HAVE PAINTED BLACK FINISH TO MATCH ALL OTHER EQUIPMENT PROVIDED BY A/C. INSTALLER TO ARRANGE REPAINTING TO MATCH BUILDING EXTERIOR IF REQUIRED.

OUTSIDE VIEW

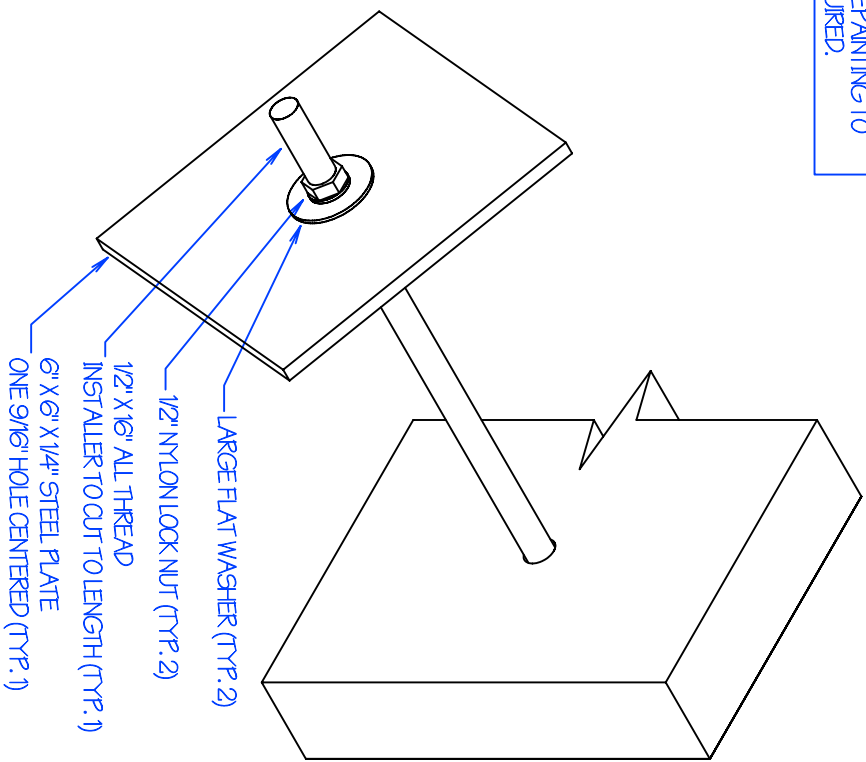

REVISION / STAGE	MONTH / DAY / YEAR

RELATED DRAWINGS / INFORMATION

D-6.3

THRU WALL ATTACHMENT DETAIL

D-6.3

THIS DRAWING IS PROPERTY OF ARIZONA COURTLINES, INC. AND MAY NOT BE REPRODUCED WITHOUT WRITTEN PERMISSION.

ARIZONA COURTLINES, INC.

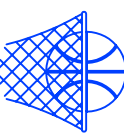

8742 NORTH 72ND AVENUE
 PEORIA, ARIZONA 85345
 PHONE (623) 939-8726
 FAX (623) 939-2526
 WWW.ARIZONACOURTLINES.COM

DRAWN BY:

EDDIE CAFFERATA

CHECKED BY:

QUANTITY:
