

THIS ATTACHMENT MUST BE APPROVED AND STAMPED BY THE PROJECT STRUCTURAL ENGINEER.

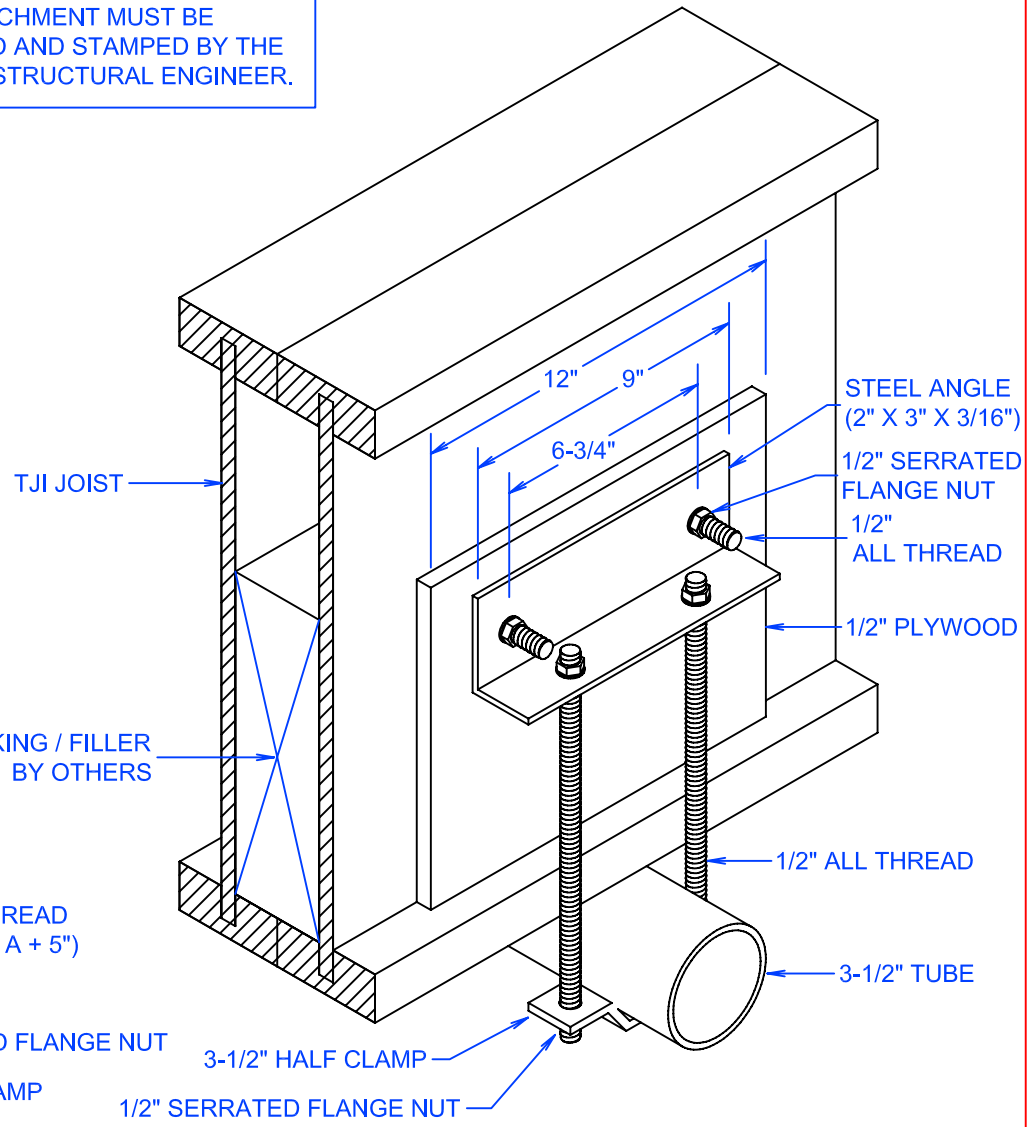
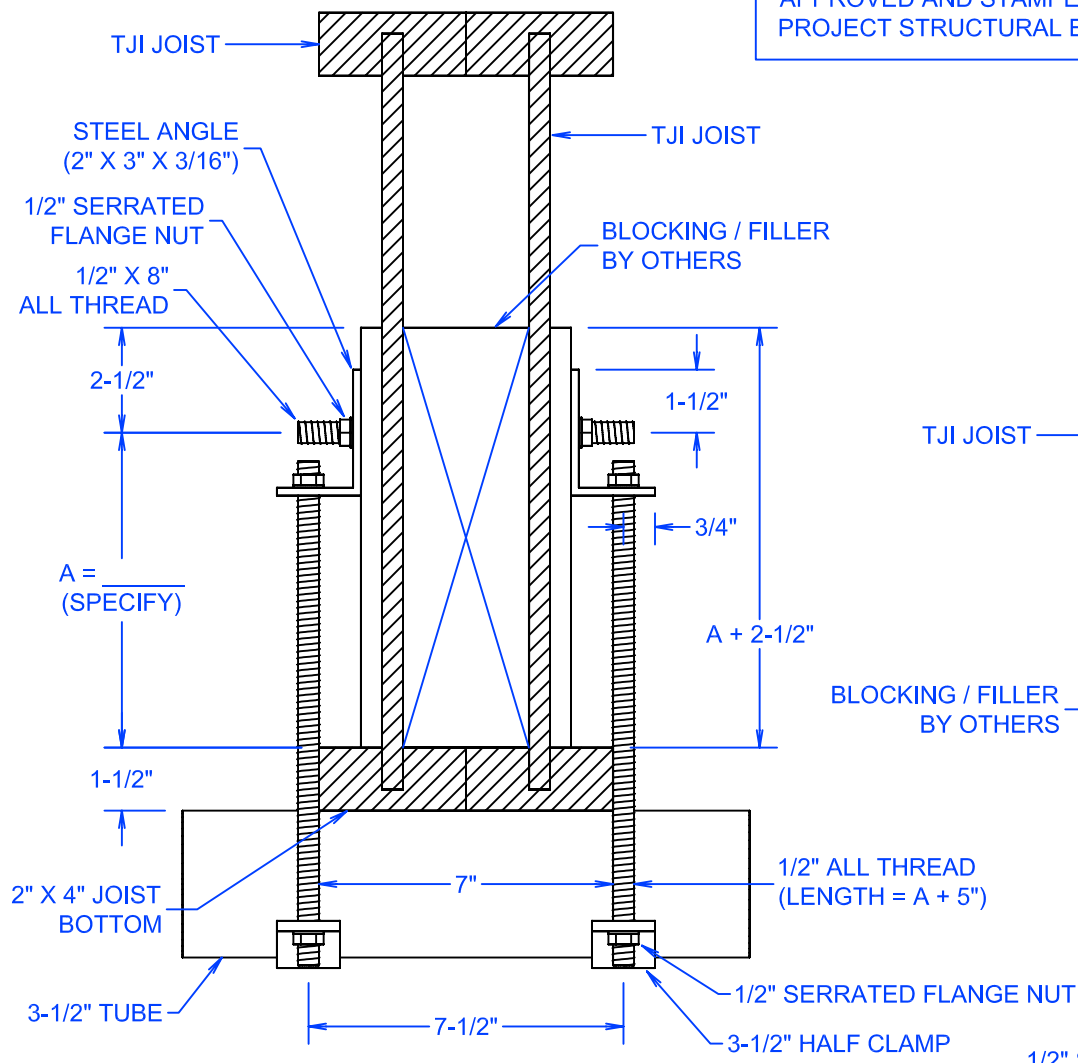

REVISION / STAGE:	MONTH / DAY / YEAR	RELATED DRAWINGS / INFORMATION:
D-4.65		THIS DRAWING IS PROPERTY OF ARIZONA COURTLINES, INC. AND MAY NOT BE REPRODUCED WITHOUT WRITTEN PERMISSION

D-4.65

**DOUBLE TRUS JOIST I-JOIST (TJI)
ATTACHMENT**

ARIZONA COURTLINES, INC.



8742 NORTH 78TH AVENUE
PEORIA, ARIZONA 85345
TEL. 623.939.8126
FAX. 623.939.2526
www.ARIZONACOURTLINES.com

DRAWN BY:
EDDIE CAFFERATA

CHECKED BY:

QUANTITY: