

THIS ATTACHMENT MUST BE APPROVED AND STAMPED BY THE PROJECT STRUCTURAL ENGINEER.

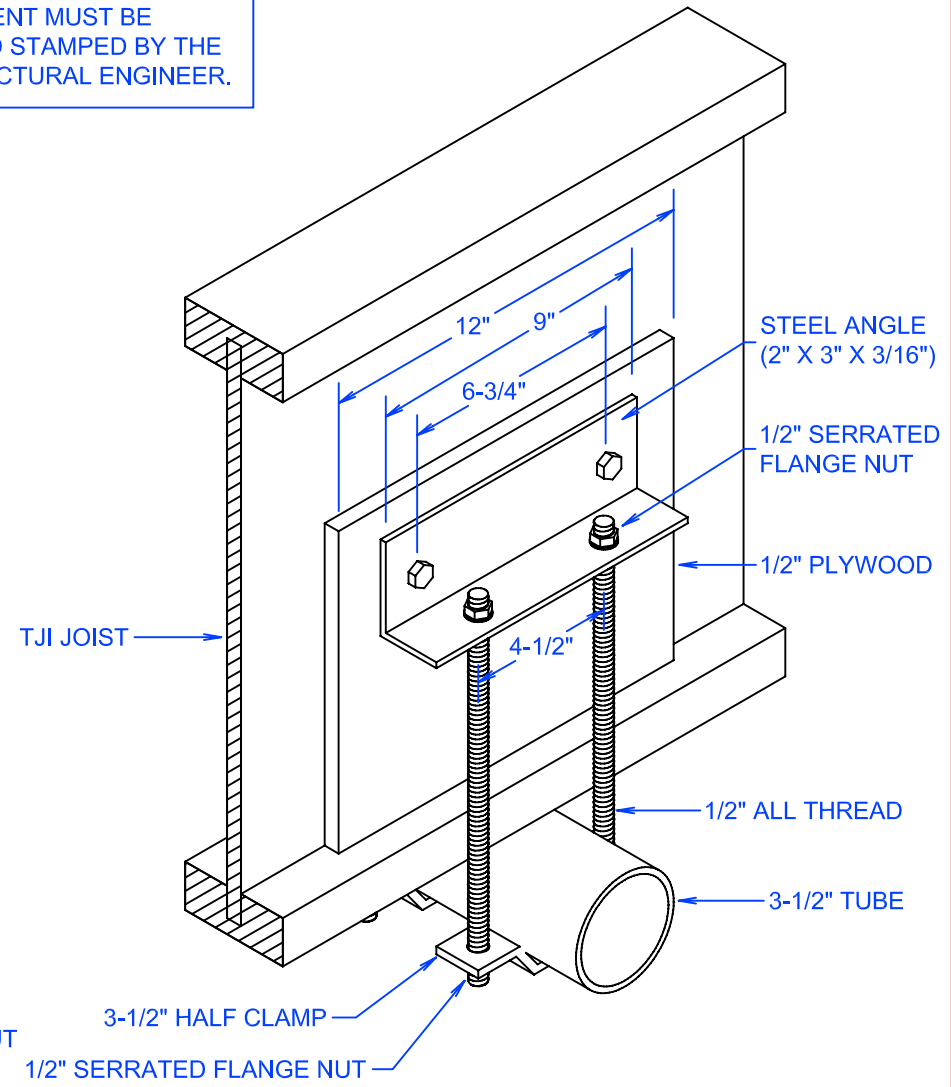
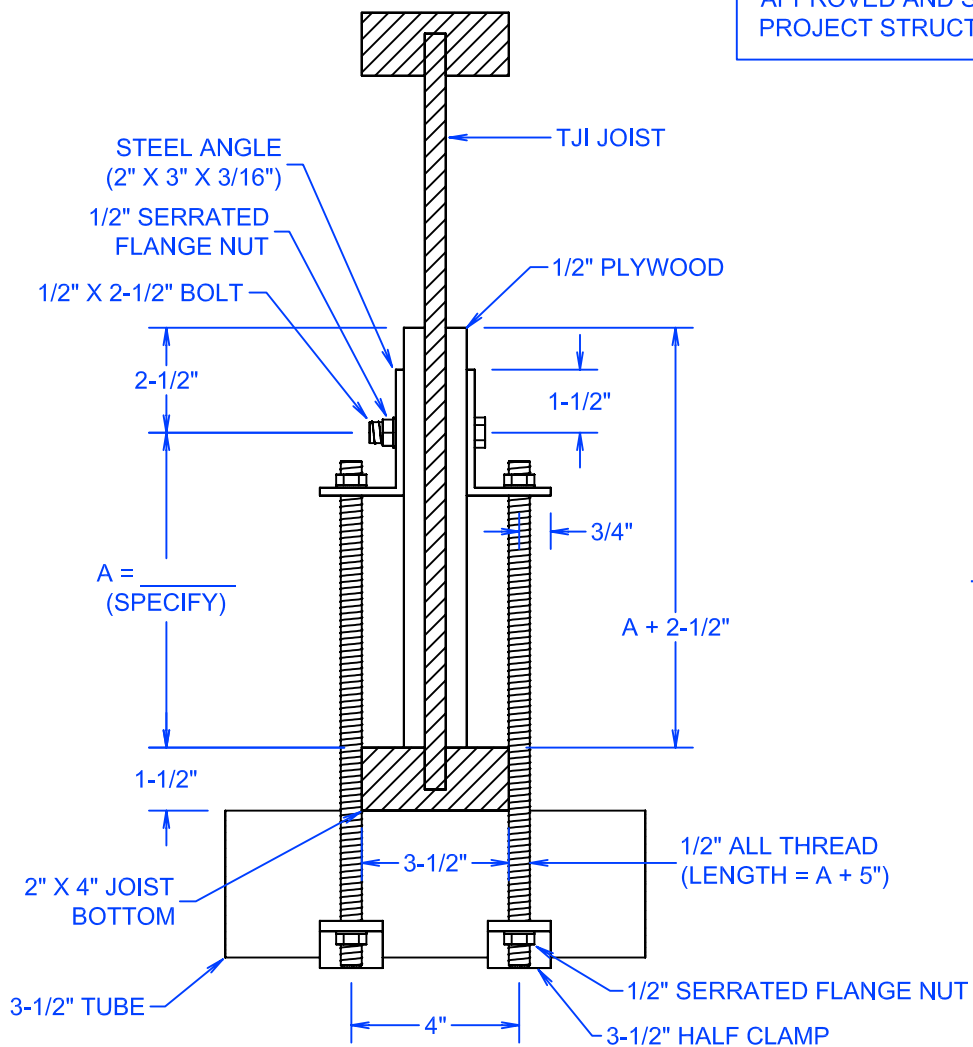

REVISION / STAGE:	MONTH / DAY / YEAR	RELATED DRAWINGS / INFORMATION:
D-4.6		THIS DRAWING IS PROPERTY OF ARIZONA COURTLINES, INC. AND MAY NOT BE REPRODUCED WITHOUT WRITTEN PERMISSION

D-4.6

**TRUS JOIST I-JOIST (TJI)  
ATTACHMENT**

ARIZONA COURTLINES, INC.



8742 NORTH 78TH AVENUE  
 PEORIA, ARIZONA 85345  
 TEL. 623.939.8126  
 FAX. 623.939.2526  
 www.ARIZONACOURTLINES.com

DRAWN BY:  
 EDDIE CAFFERATA

CHECKED BY:

QUANTITY: